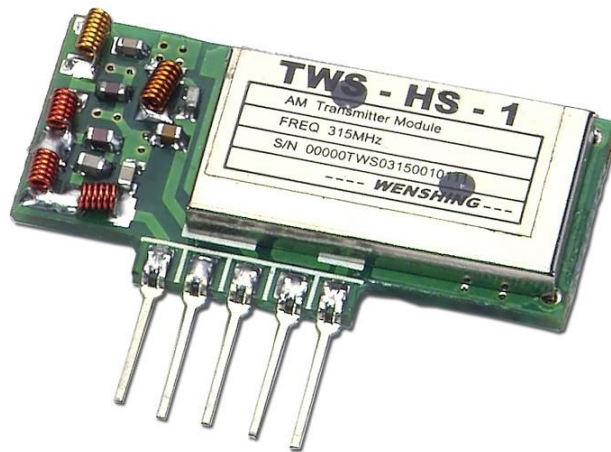

Wireless High Power Transmitter Module (RF ASK)

**Version History**

Version	Date	Changes
V1.01	Dec.13,2002	1 st . Edition
V1.02	Aug.20, 2007	2 nd . Edition
V1.03	Mar.15, 2008	3 rd . Edition
V1.04	Jul.16, 2009	4 th . Edition

Key Feature

- Output Power up to 0.5W
- Voltage Supply from 4.5V to 5.5V
- Transmitter Data Rate 8Kbps

Application

- Remote control aircraft
- Remote control alarm
- Wireless toy
- Long-distance switch
- Long-distance walkie-talkie

Characteristic

Parameter	Min	Type	Max	Unit	Condition
Operating Conditions					
Operating Temperature Range	-10		+70	°C	
Soldering Temperature			+230	°C	10sec
Operating Supply Voltage	4.5		5.5	V	
Current Consumption					
Tx Mode			270	mA	0.5W
Standby Mode			33	mA	E/D=H
TWS-HS Series for Frequency					
TWS-HS-1	314.9	315	315.1	MHz	ASK
TWS-HS-2	433.82	433.92	434.02	MHz	ASK
TWS-HS-3	868.25	868.35	868.45	MHz	ASK
RF Characteristic					
Span Range	-100		+100	KHz	
Data Rate			8	Kbps	ASK
Output Power			27	dBm	0.5W
Turn On/Off Time			300	us	
Modulation		ASK			

Block Diagram

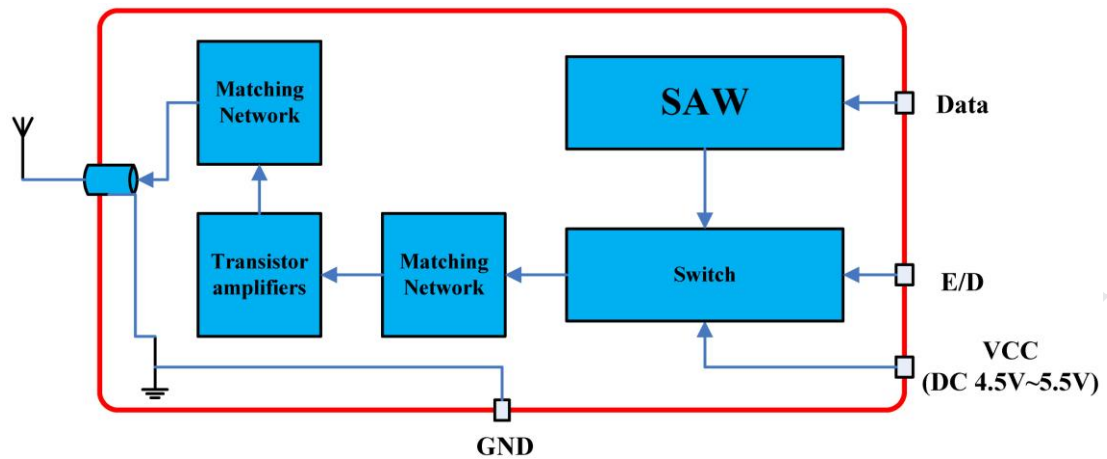

View

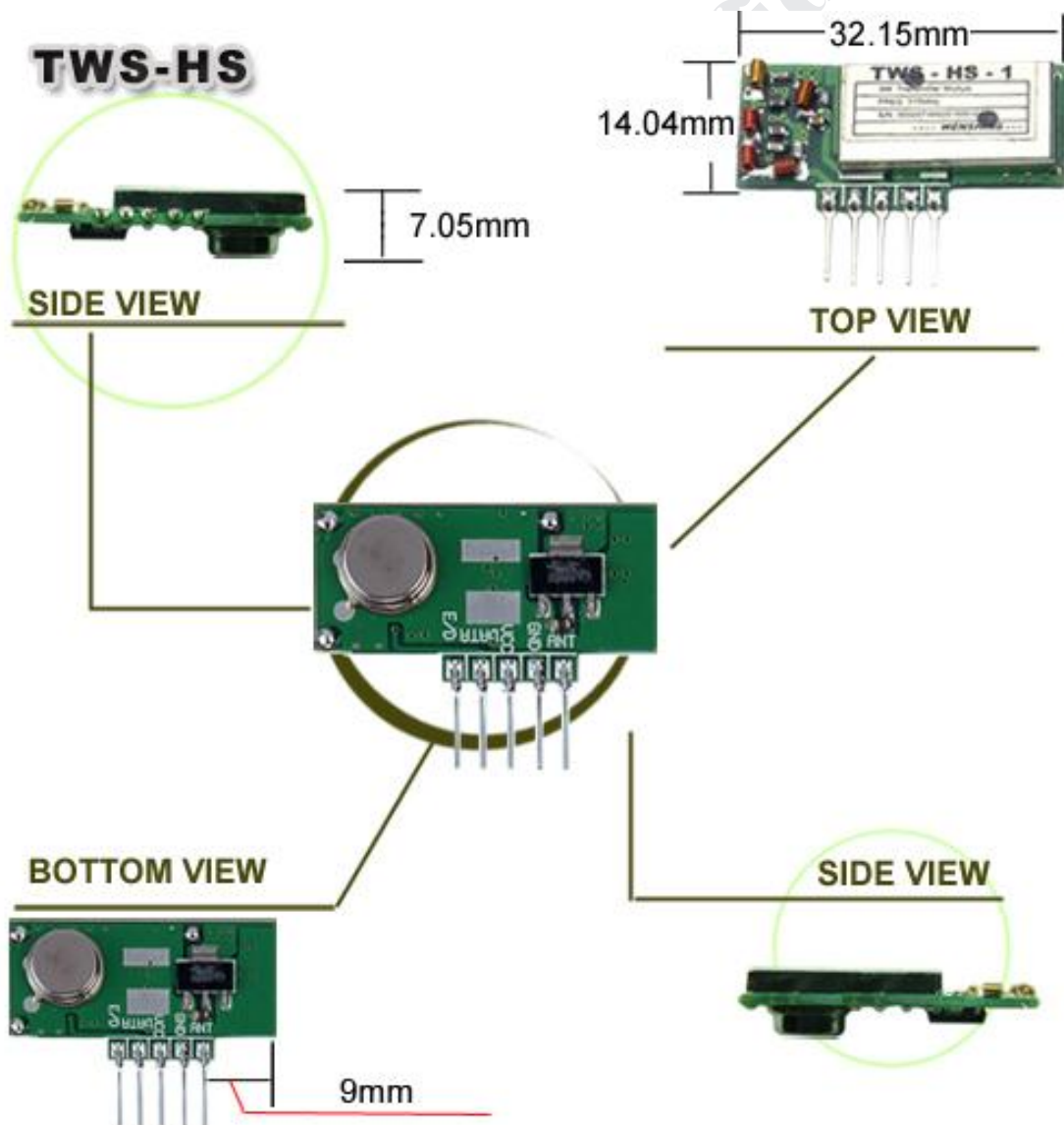

Pin Assignment

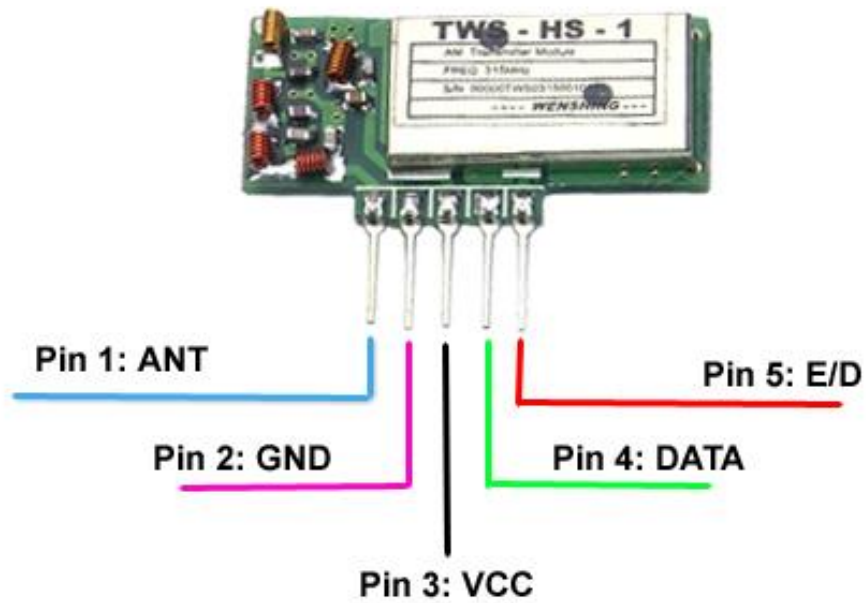

Pin	Function	I/O	Description
1	ANT	ANT	Antenna Interface
2	GND	G	Power Negative
3	VCC	P	Power Cathode
4	DATA	I	Data input
5	E/D	I	Enable and Disable Control

Timing Diagram

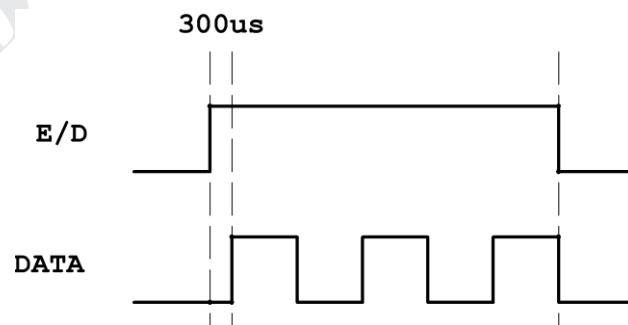

Application Circuit

