

---

 925MHz Wireless RF Hi Power Transceiver Module
 

---

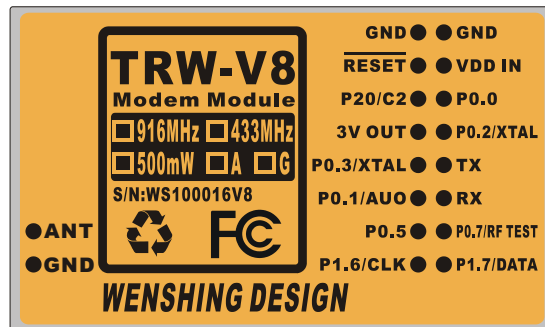

## Version History

Version	Date	Changes
V1.01	July. 29, 2010	1 <sup>st</sup> . Edition

WENSHING **TRW-V8-925-L** wireless high power transceiver RF module is designed, developed and manufactured as contemplated for general use, without limitation, ordinary industrial use, general office use, personal use, and household use, but is not designed, developed and manufactured as contemplated (1) For use accompanying fatal risks or dangers that, unless extremely high safety is secured, could have a serious effect to the public, and could lead directly to death, personal injury, severe physical damage or other loss (i.e., nuclear reaction control in nuclear facility, aircraft flight control, air traffic control, mass transport control, medical life support system, missile launch control in weapon system). (2) For use requiring extremely high reliability (i.e., submersible repeater and artificial satellite). You shall not use this product for the above-mentioned using. If your equipment is likely to be used for the above-mentioned uses, please consult with our sales representative before using. WENSHING Component Division shall not be liable against you and/or any third party for any claims or damages arising in connection with the above-mentioned uses of this product.

### Frequency Band

Module No.	TRW-V8-433-X-X	TRW-V8-868-X-X	TRW-V8-916-X-X	TRW-V8-925-X-X
Frequency Range	431~435MHz	865~867MHz	902~928MHz	925~928MHz
Power Correspondence	TRW-V8-433-L-X	TRW-V8-868-L-X	TRW-V8-916-L-X	TRW-V8-925-L-X
	Output 50mW	Output 50mW	Output 50mW	Output 50mW
	TRW-V8-433-P-X	TRW-V8-868-P-X	TRW-V8-916-P-X	TRW-V8-925-P-X
	Output 500mW	Output 500mW	Output 500mW	Output 500mW
Optional	Module No. Description: <ul style="list-style-type: none"> <li>● If the last section of module No. is G, which means this module has G sensor</li> <li>● If the last section of module No. is P, which means this module has Pressure sensor</li> <li>● Every model of this module has TEMP sensor. All optional parts can be added to the module.</li> </ul>			

## Japan Frequency Band

Module No.	TRW-V8-426-X-X	TRW-V8-429-X-X	Remark
Frequency Range	426.025MHz	429.25~429.7375MHz	(25KHz 間隔のみ)
Power Correspondence	1mW, 10mW	1mW, 10mW	動作コマンドで設定切替え
Optional	Module No. Description: <ul style="list-style-type: none"> <li>● If the last section of module No. is G, which means this module has G sensor</li> <li>● If the last section of module No. is P, which means this module has Pressure sensor</li> <li>● Every model of this module has TEMP sensor. All optional parts can be added to the module.</li> </ul>		

## Function Introduction

TRW-V8-925-L is wireless high power data two-way transceiver RF module. The key feature of this module is its resilience against interference, which way surpass traditional wireless module. The build in Saw Filter can remove unnecessary interference signals. When the transmitting distance is not far enough during operational environment, relay protocol station can be used to forward signal; also, transmitting to other interface if it is required.

This module is fully digitalized structure designed, there is no adjustment required. This module includes UR and I2C interface, which provide convenience communication. Also, we can modify software, including special monitor point for voltage (A/D), current, output voltage (D/A) according to customer demand. End product requirement can be met without add MCU; this will save designing time for user.

Another key feature of TRW-V8 is its wide operating temperature, which is between -20 and +70°C. The build-in AFC can auto-lock frequency, there is no need to worry about frequency shifting after long period of operation.

TRW-V8-925-L has wide range of usage other than transmitting date. This module can vibration collector, (detecting landslides) and weather detection. Other function can be added accordingly; also, software can be changed, this module is convenient and easy to use.

## Application

- Safety Monitoring System
- 900MHz Wireless Cordless
- Wireless Remote Control Car
- Wireless Remote Control Robot
- Meter, Water Meter, Coin Data Acquisition
- Wireless Modem
- Debris Flow Detection Point
- Weather Detection point
- Wireless Transmission network Transfer Function
- WSN

## Electrical Specification

### TRW-V8-925-L

Parameter	Specification			Unit	Condition
	Min	Type	Max		
Frequency Range		925		MHz	
Receiver Sensitivity	-127		-98	dBm	1.2Kbps test
Data Rate	1.2		250	K Bit	GFSK
Supply Voltage, VDD	4		5	V	DC
TX Current	252		284	mA	
RX Current			30	mA	
Output power	+26.1dBm		+27.5dBm		+27dBm=500mW
Sleep Current				uA	Option: Only module with 32.768 KHz Crystal has energy saving function.
Power up time			100	ms	Time after Power-up
Operating Temperature	-20	+27	+70	°C	

## Internal Block Diagram

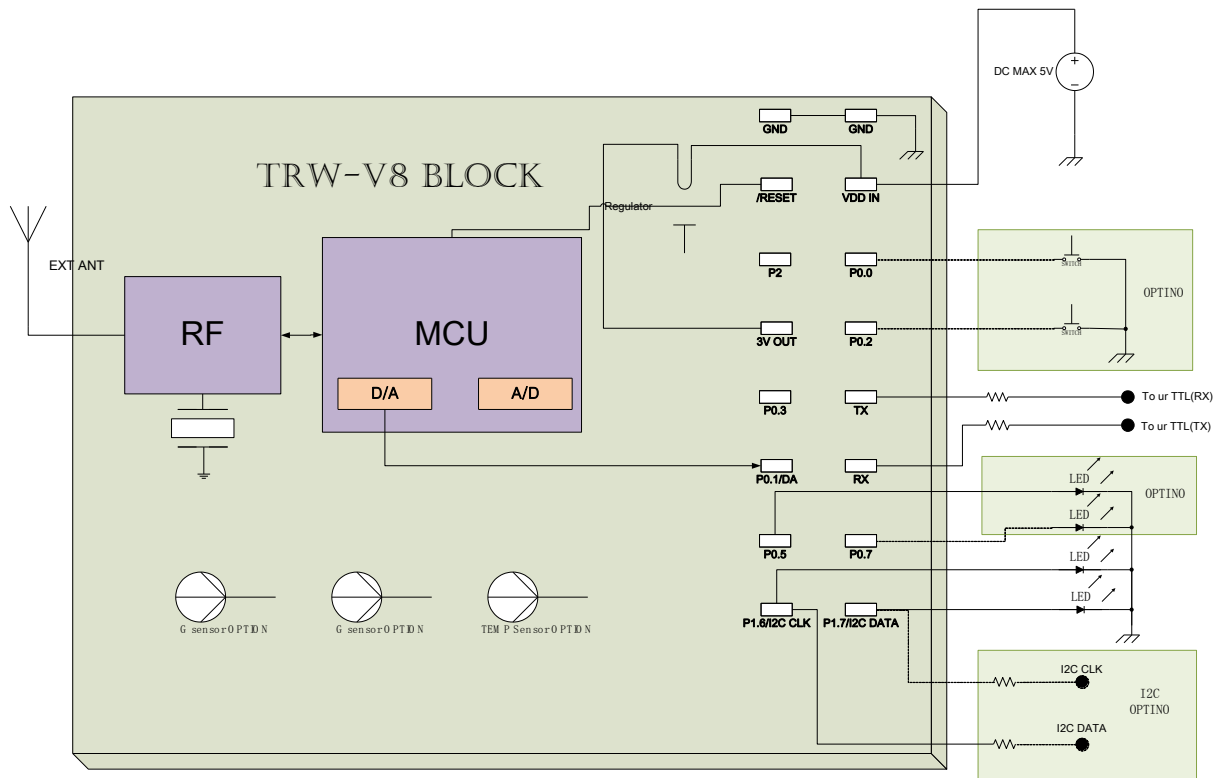

## Absolute Maximum Rating

Minimum	Maximum	Units	Operating conditions
<b>Supply voltages</b>			
-0.3	5.5	V	VDD
	0	V	GND
<b>Input voltage</b>			
-0.3	3.6	V	VI(DATA IN)
<b>Output voltage</b>			
GND TO 3	GND TO 3	V	VO

# Size

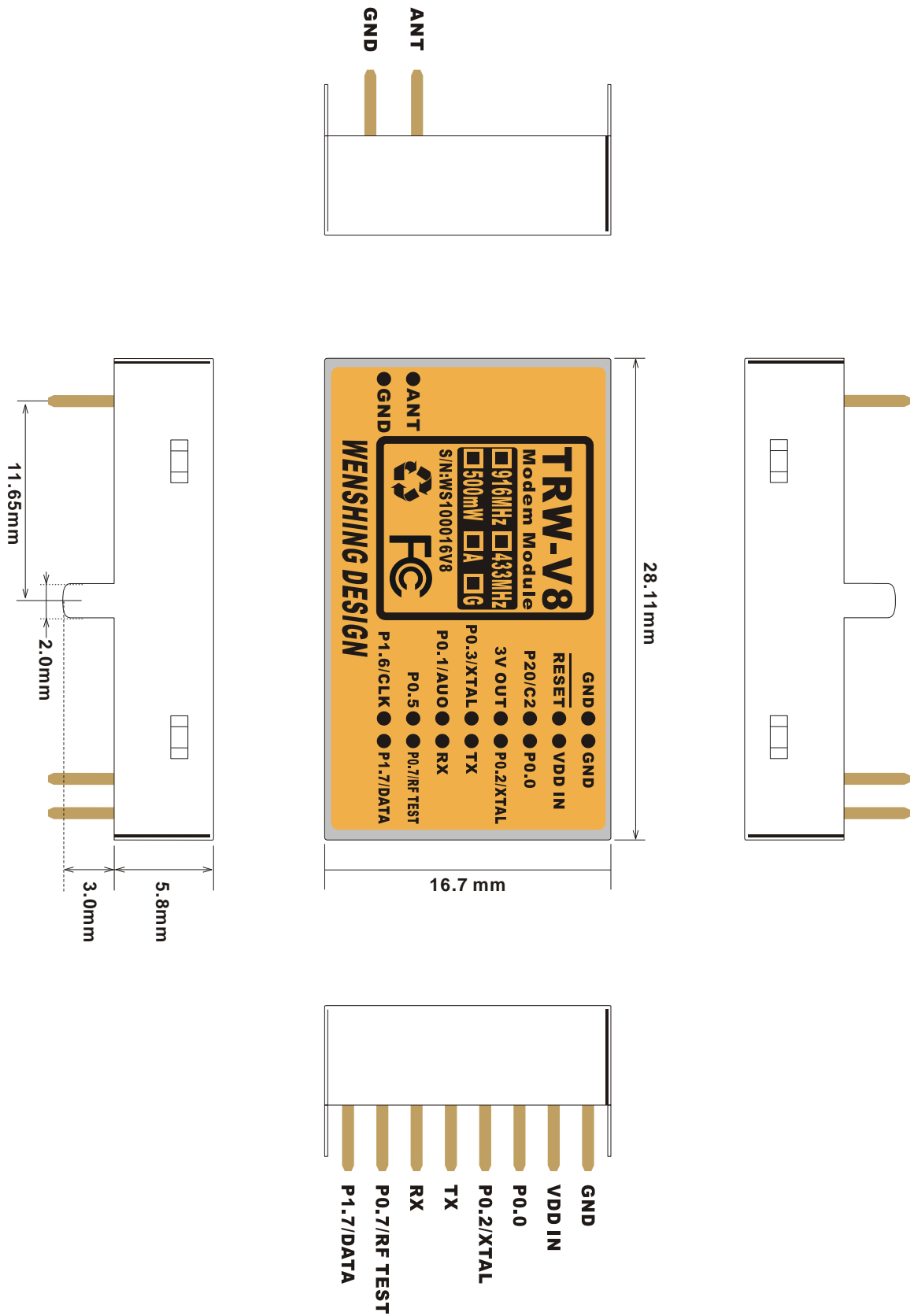

## Pin Assignment

Pin	Name	I/O	Description
1	ANT	I/O	To ext Antenna
2	GND	RF GND	RF GND
3	GND	Ground	Ground
4	/RESET	I	Active low module reset
5	P20	I/O	General I/O usage
6	3V OUT	POWER	3V output can connect to current under 50mA.
7	P2.0/Crystal	I/O	General I/O usage, Option: can connect to 32.768KHz Crystal
8	P0.1/AUO	I/O	General I/O usage, Option: can be Data converted to analog (D/A)
9	P0.5	I/O	General I/O usage, Option: can be analog converted to Data (A / D)
10	P1.6/CLK	I/O	General I/O usage, Option: can be used as I2C CLK
11	P1.7	I/O	General I/O usage, Option: can be used as I2C Date
12	P0.7	I/O	General I/O usage, (for producing test RF Pin)
13	RX	I	UR interface,(TTL 3V), can connect to RS-232 Chip TX
14	TX	O	UR interface,(TTL 3V), can connect to RS-232 Chip RX
15	P0.2/Crystal	I/O	General I/O Usage, Option: can connect to 32.768 KHz Crystal
16	P0.0	I/O	General I/O Usage,
17	VDD IN	POWER	Power Supply 3.7~5.5V
18	GND	Ground	Ground

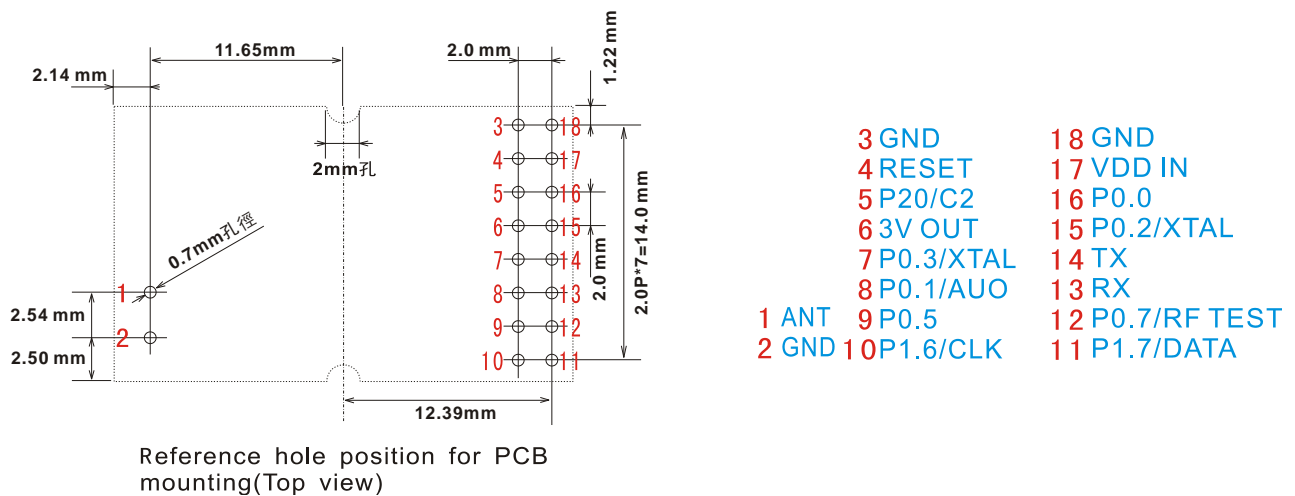

## Circuit Example 1

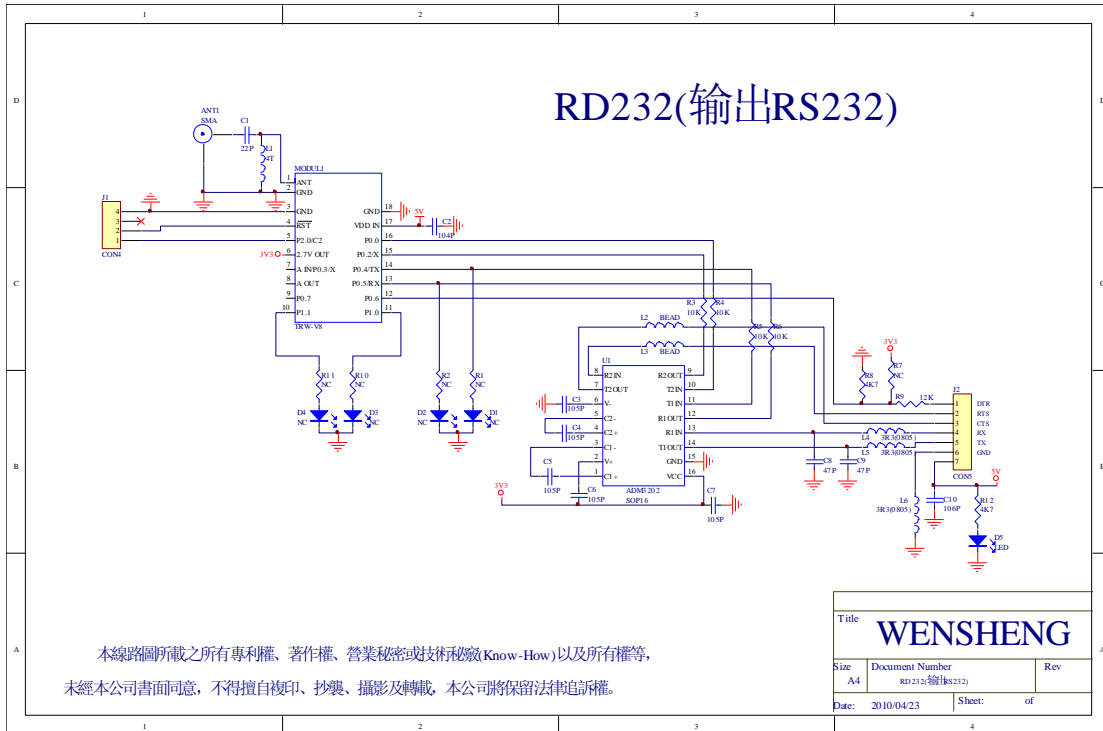

## Circuit Example 2

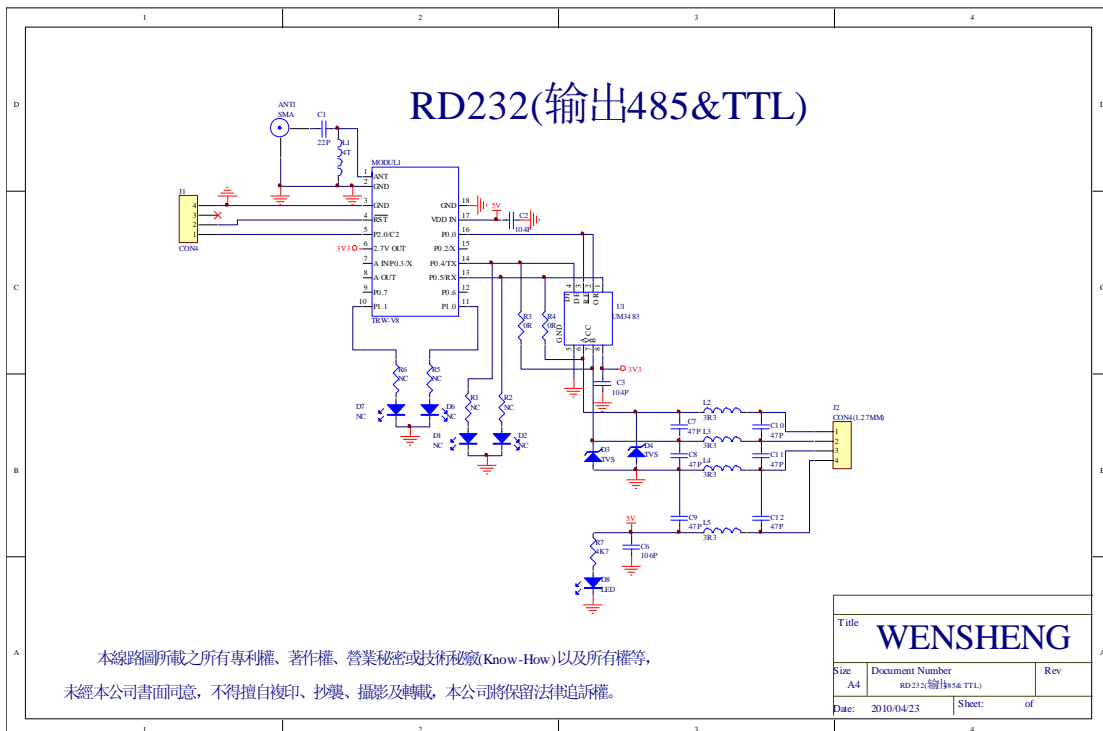

## Layout Notes

- It should be to add several big capacitors before power on to increase stable RF communication.

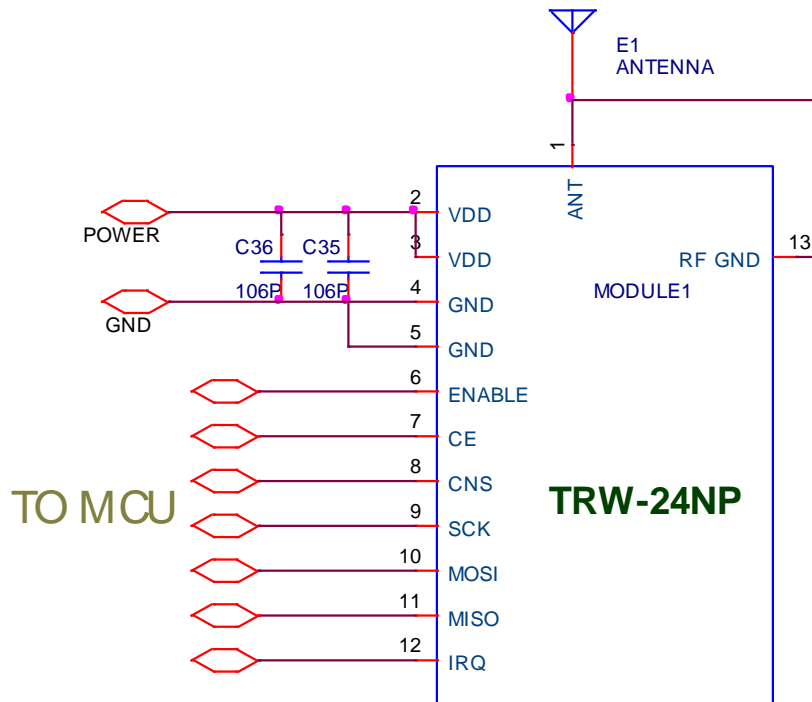

- It should not run digital signal at end of module to avoid EMI transmitted to RF module.
- Module add external antenna, the bottom part of the PCB antenna should be as much as possible to provide non- copper park area for the antenna radiation use.