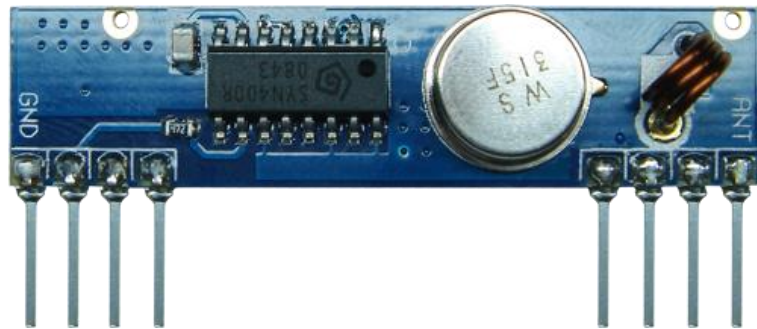

Wireless Narrow Band Receiver Module (RF ASK)

**Version History**

Version	Date	Changes
V1.01	Nov. 23, 2009	1 st . Edition
V1.02	Mar. 08, 2010	1 st . Edition

Function Introduction

This wireless high-frequency receiver module RWS-434N is through WENSHING R&D team assembled many years of experience to develop this high sensitivity OOK receive module. Lost cost, high stable also can provide the best RF solution in the market.

Design ideal is to use SAW filter, highly suitable for industry control or bad place for use, strong anti-jamming. Built-in automatic gain circuit (AGC), it will automatically change front-end LNA gain among received signal strength also makes signal output will not be strong or weak signals which caused by phase distortion, so that it can rise higher sensitivity. To receive the local oscillation circuit for the PLL lock loop design, no offset, and stability is high.

Frequency is 315MHz and receiver structure is super heterodyne, received signal is OOK. After received signal, it will output TTL signal to external decoder IC for decoding.

It is convenience to use in different products and external components is not necessary to make products be wireless also bring value-added for your products.

Model: RWS-434N-3

● 315MHz Lost cost Receiver Module
● Build-in AGC
● Low Working Voltage 3.5V~5.5V
● Low Current 5.7mA
● High Sensitive -117dBm

Application

Security System

Wireless Remote Control Car

Wireless Remote Control Robot

Automatic Power Switch Control

Electrical Specification

Parameter	Specification			Unit	Condition
	Min	Type	Max		
Frequency Range	314.70	315	315.30	MHz	
Receiver Sensitivity	-114		-117	dBm	
Data Rate	0.058		12	K Baud	
Supply Voltage, VDD	3.5		5.5	V	DC
Current	5.7		7.3	mA	
Operating Temperature	-20		+70	°C	

Pin Assignment

Pin	Pin Name	Description
1	ANT	RF Input
2	GND	RF GND
3	GND	RF GND
4	Vcc	Power Supply V+
5	Vcc	Power Supply V+
6	NC	--
7	DATA	Digital DATA Output
8	DGND	Power Supply GND

Internal Block Diagram

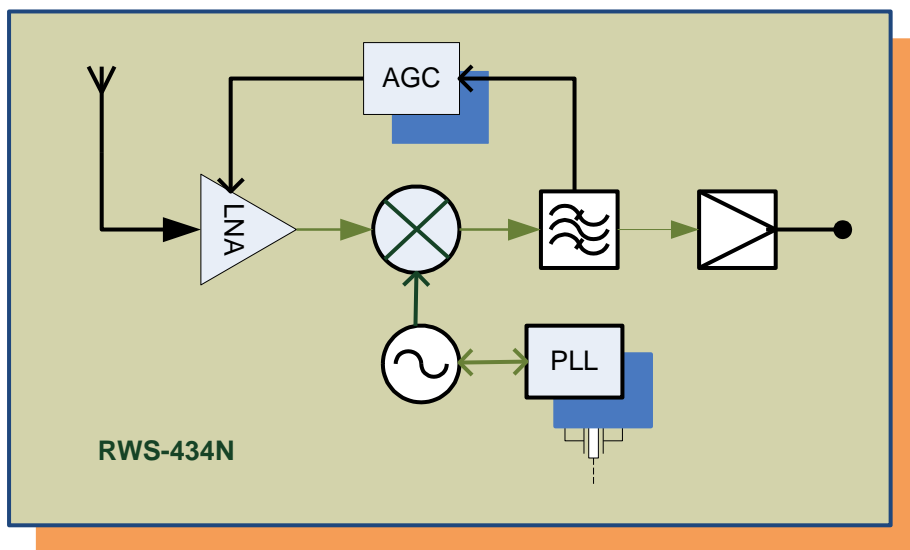

Size

(unit: mm)

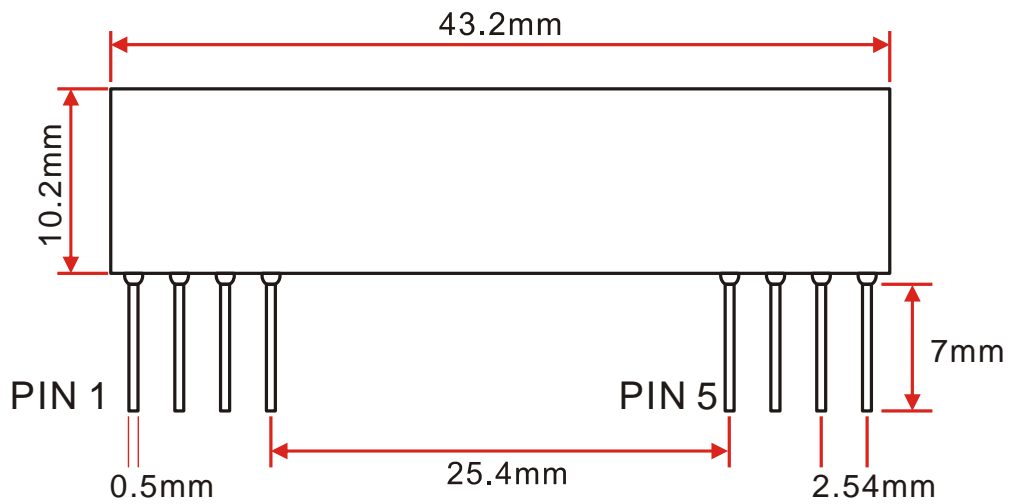

LAYOUT Notice

Power supply is by 5PIN VCC and 8PIN GND provide electronic. Do not let DGND connect with RF GND to prevent MCU EMI interfere RF received signal. Please check example of design.

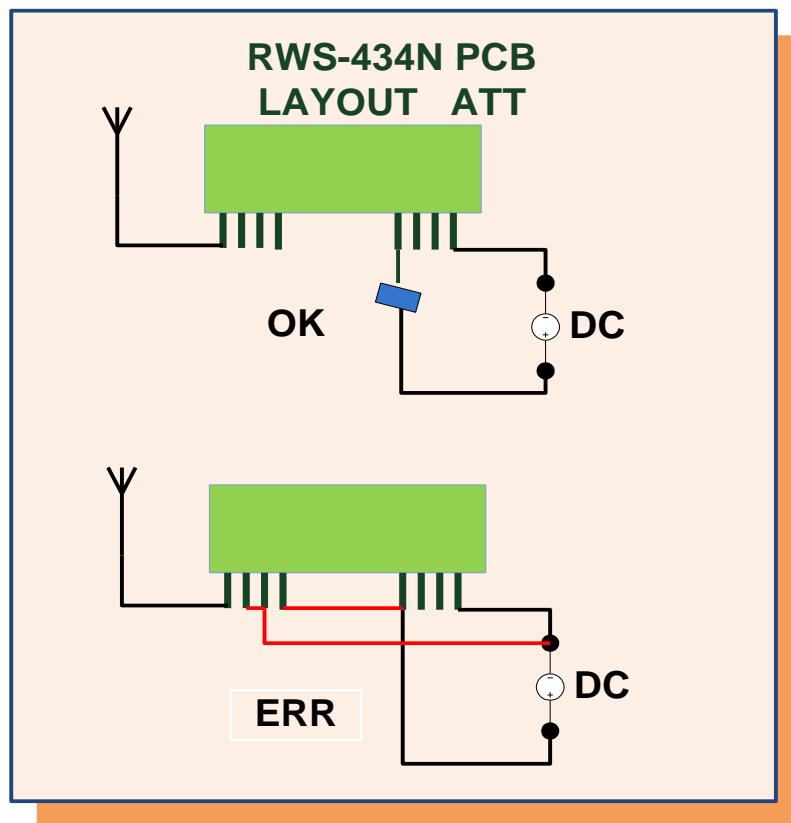

Application Circuit

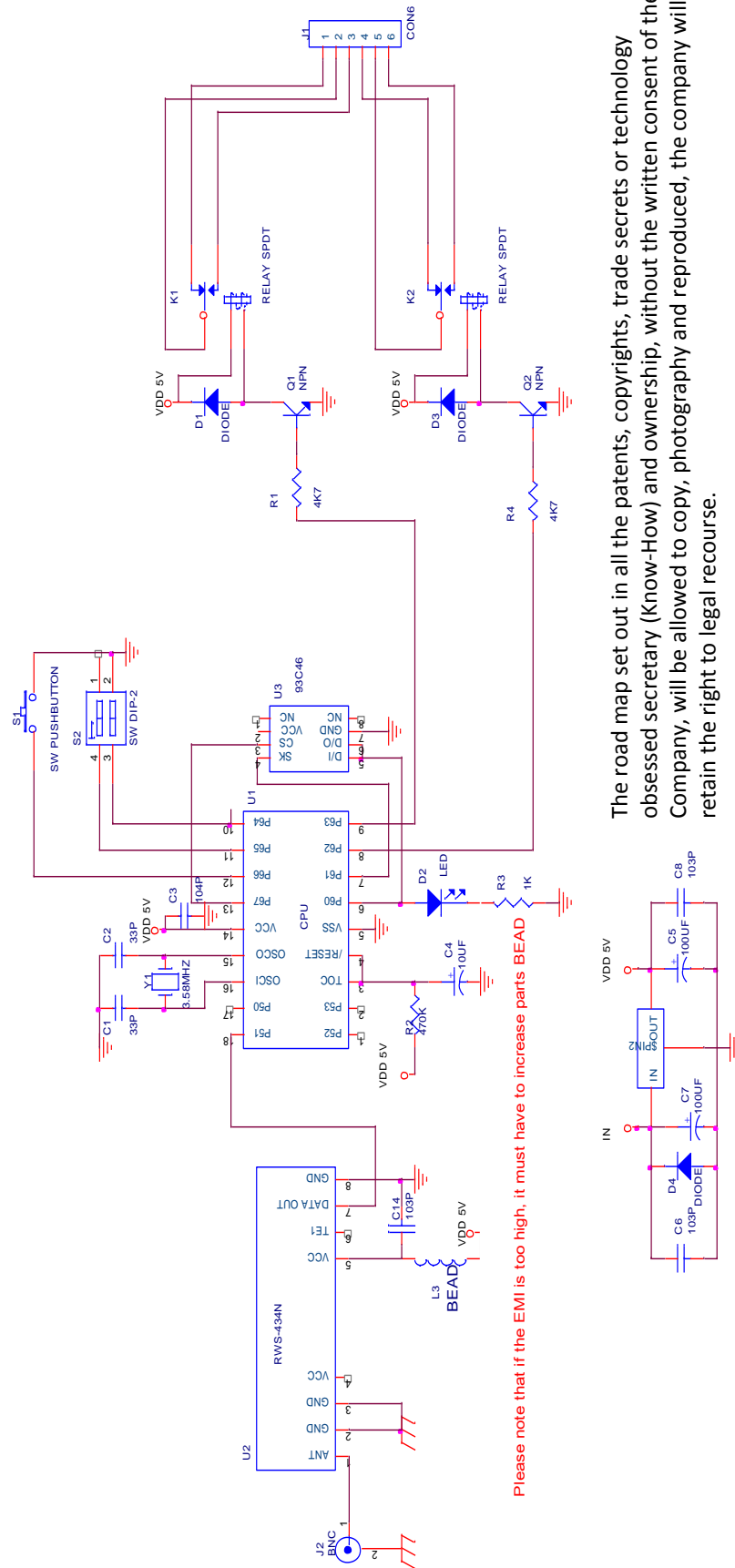

The road map set out in all the patents, copyrights, trade secrets or technology obsessed secretary (Know-How) and ownership, without the written consent of the Company, will be allowed to copy, photography and reproduced, the company will retain the right to legal recourse.